

USES, OPERATION, DESIGN CONSIDERATIONS AND LOAD RATINGS OF ON-OFF TOOL

Ricky Roderick
Jyothi Swaroop Samayamantula
Don-Nan Pump & Supply

ABSTRACT

The scope of this paper includes a brief introduction about On-Off tool, design and construction, their applications, operational procedures, and general load carrying capabilities. The paper discusses some advantages gained by installing an On-Off tool such as, the ability to repair or replace the rod string without unseating the pump, the ability to break the sucker rod string just above the pump eliminating stripping job and the ability to run oversized tubing pumps.

ON-OFF TOOL

The On-Off tool provides an operator with a means of connecting to or disconnecting from a sucker rod string, at any point, based on the location of the tool in the rod string. The On & Off tool is attached directly to the sucker rod string, and located in a well at a point where the operator wishes to make the disconnection. The tool is disconnected by turning the rod string, and picking up, it is connected by setting down weight in the bottom latch section and rotating the rod string, in the opposite direction.

ADVANTAGES & APPLICATION

The use of the On-Off Tool offers the following operational advantages;

- Virtually eliminating stripping jobs which always result in higher cost due to increased rig time and damaged equipment.
- Providing a means of running oversize tubing pumps permitting the use of larger plunger for displacing more fluid without replacing the entire tubing string.
- In crooked holes, metal plungers for tubing pumps may be run in the well in the barrel assembly eliminating the possibility of damaging the plunger while lowering it through the tubing on the sucker rod string.
- Permits the operator to “fish” broken rods without unseating the pump, and dumping the fluid “head” on the producing formation. This may result in damage to the reservoir.
- Many operators should periodically run scrapers in wells with severe paraffin conditions. This is best accomplished by unseating the pump and raising and lowering the rod string to assist in removing paraffin from the tubing wall. This normally results in damaged seating cups resulting in removal of the pump from the well for repairs. The On-Off Tool permits this operation without unseating the pump, without dumping the fluid in the tubing string, and also assists in reducing rig time.
- It may be used with “Bottled Up” Pumps. It helps in reducing the cost of having bigger tubing above the pump location. Still a larger pump bore can be used by having bigger tubing just at the pump location.
- Can be used in sandy wells, where it is difficult to pull the pump assembly.
- It may also be used as a Safety Joint.

DESIGN & FUNCTIONALITY

The On-Off tool is an assembly of six different components: Top Bushing (Figure 1), Body (Figure 2), Locking Pawl (Figure 3), Balls (Figure 4), Bottom Latch (Figure 5), Spring (Figure 6).

These parts can be manufactured in different metallurgies as required by different well conditions. This tool can be produced for both right hand as well as left hand operation. The outer diameter of the assembly is designed to match with the outer diameter of the sucker rod coupling (with few exemptions) for the free movement of the tool along the tubing.

The body of the tool has a spiral like profile as shown in the figure 2; it has ball guides machined above the profile. The locking pawl with the inserted balls inside is inserted in to the body by letting the balls roll along the ball guides

that are machined in the body. The balls in the guides help keep the locking pawl from rotating during the latching and unlatching operations of the tool. A spring of sufficient strength is dropped on top of the locking pawl in the body (more than one spring can be used for extra compressive strength (Figure 8)). This spring is compressed against the locking pawl with the help of a bushing (Figure 1). This bushing is provided with a sucker rod thread at the top, which is connected to the sucker rod string. During the latching operation, the body assembly (consisting of the top bushing, spring, balls and the locking pawl) is lowered so the head of the bottom latch may enter the body and strike the spiral like profile. This profile guides the bottom latch into the oval shaped hole in the body. The head strikes the locking pawl and the spring gets compressed as the pawl is pushed further. As soon as the shoulder of the head of the bottom latch passes the body ledge, the locking pawl rotates the bottom latch by turning the head 90° thus locking the shoulder against the ledge.

To unlatch the tool, pickup the weight of the rods in fluid to reduce the friction between the body and the bottom latch. Now by rotating the body assembly, the head of the bottom latch drives the locking pawl upwards compressing the spring. This rotation aligns the oval shaped hole in the body with the head of the bottom latch eliminating contact between the head and the ledge, disengaging the tool.

OPERATING PROCEDURES:

Positioning of the Tool

- When used as a “Safety Joint” it should be positioned a minimum of three to four sucker rods above the pump or higher should sandy conditions exist.
- When used to run oversize tubing pumps, a pony rod of sufficient length to place the “On & Off” tool up in the tubing string should be attached with the plunger in the bottom most position.

Running the Tool

- If used as a “Safety Joint”, it is made up in the sucker rod string with the sucker rod pin up.

Latching the Tool

- Lower the sucker rod string until the upper section engages the bottom latch of the tool and starts to take weight. You will notice a decrease in the hook weight.
- Turn the sucker rod string to the right (approximately two complete revolutions per 1000 feet of setting depth to work the torque down the hole) to correctly position the latch in the milled spiral.
- Apply 1000 pounds (this load varies depending on the compressive strength of the spring used) of rod weight. The bottom latch compresses the spring and rotates to latched position.
- To make sure that the latch is in locked position turn the sucker rod string to the left making sure the rotation is sufficient to reach the tool. This rotates the lugs into the locked position.
- The pump assembly, tubing or insert, should always be in the clutched position when using the tool. In case of insert pumps this can be achieved by engaging valve rod bushing in the clutch slot of the valve rod guide. In case of oversize tubing pumps this can be achieved by engaging slotted seat plug with the clutch bar on the standing valve cage or by engaging the plunger assembly in the J-slot.
- If an oversize tubing pump is employed, the operator may choose to run a Standing Valve Puller so that the standing valve may be unseated and fluid column dumped, eliminating wet strings. This provides a means of pulling both the plunger and standing valve completely out of the barrel assembly – latching them in a J-slot located in the tubing string prior to actuating the “On and Off” Tool.
- Spiral Rod Guides or standard type rod guides are recommended for use immediately above and below the “On and Off” tool to assist in correctly centering it in the tubing string.

Unlatching the Tool

- During the unlatching operation, friction is exerted at two places. One is between the bottom latch and the body and the other is between the head of the bottom latch and the ledge of the body. In order to lower the friction at these two locations, pickup the weight of rods in the fluid, simultaneously keeping the pump clutches engaged.
- Rotate the sucker rod string to the right, approximately two complete revolutions per 1000 feet of setting depth to work the torque down the hole should be sufficient; however this may be increased when either 5/8 sucker rods are used or if the well is particularly crooked.
- One quarter turn at the “On and Off” Tool will disengage the tool.

- Raise the rods while maintaining the torque until the body of the On-Off tool clears the bottom latch.
- The rod string is then free to be pulled.

Load Ratings and Failures

Most of the failures that are observed in On-Off tools are on the bottom latch of the tool. This is due to the improper selection of the size and the metallurgy of the tool. It is observed that the failures are also due to improper operation while latching and unlatching the tool. When the connecting parts are rammed together, the latching profiles are distorted resulting in the inability to latch the tool. Improper selection of the tool size will lead to overloading and results in the failure of the bottom latch. The tool undergoes fatigue stresses due to the cyclical nature of the applied loads during the pumping cycle. The tool size and metallurgy should be carefully selected to keep it from overloading. The load ratings of the tool can be found by the Modified Goodman Diagrams. These load rating values vary between manufacturers. It is highly recommended that the operator obtain dynamometer readings to determine the applied load at the tool, prior to the installation.

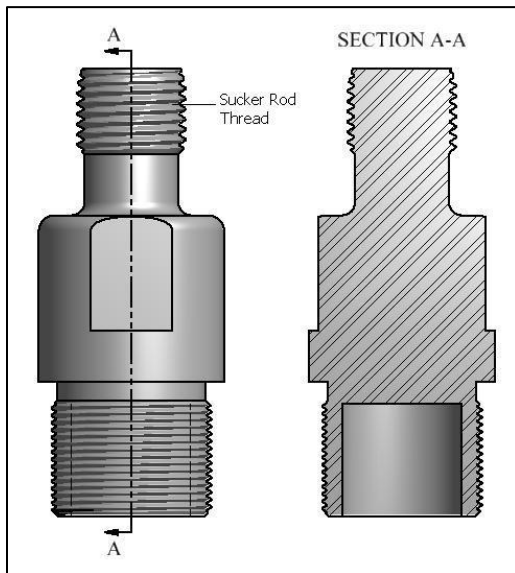

Top Bushing (Figure 1)

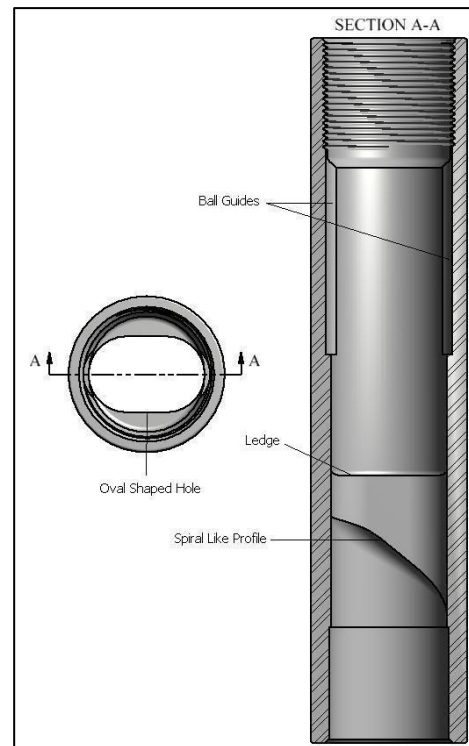

Body (Figure 2)

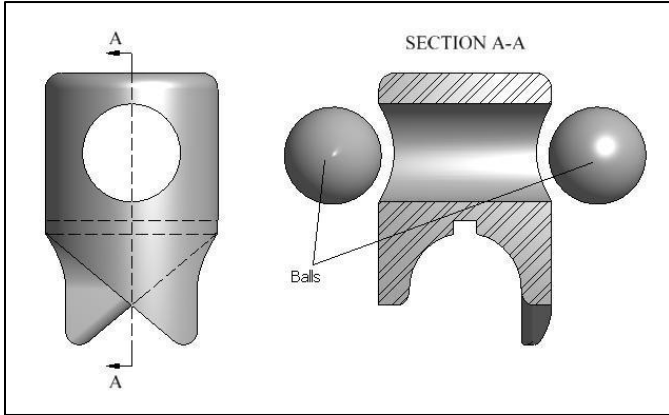

Locking Pawl with Balls (Figure 3, Figure 4)

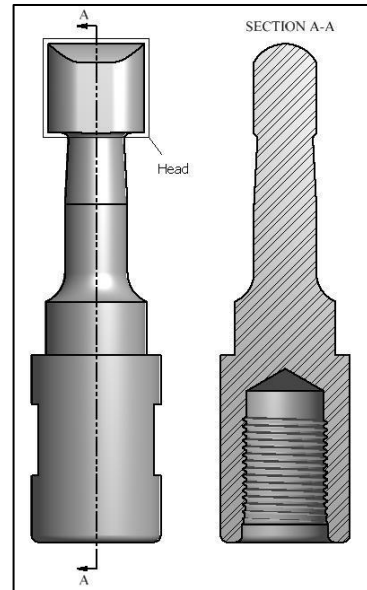

Bottom Latch (Figure 5)

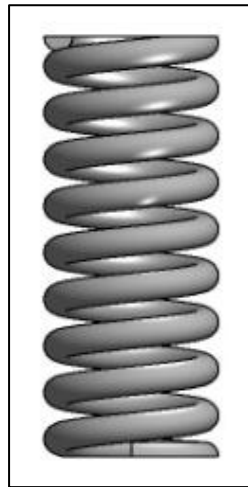

Spring (Figure 6)

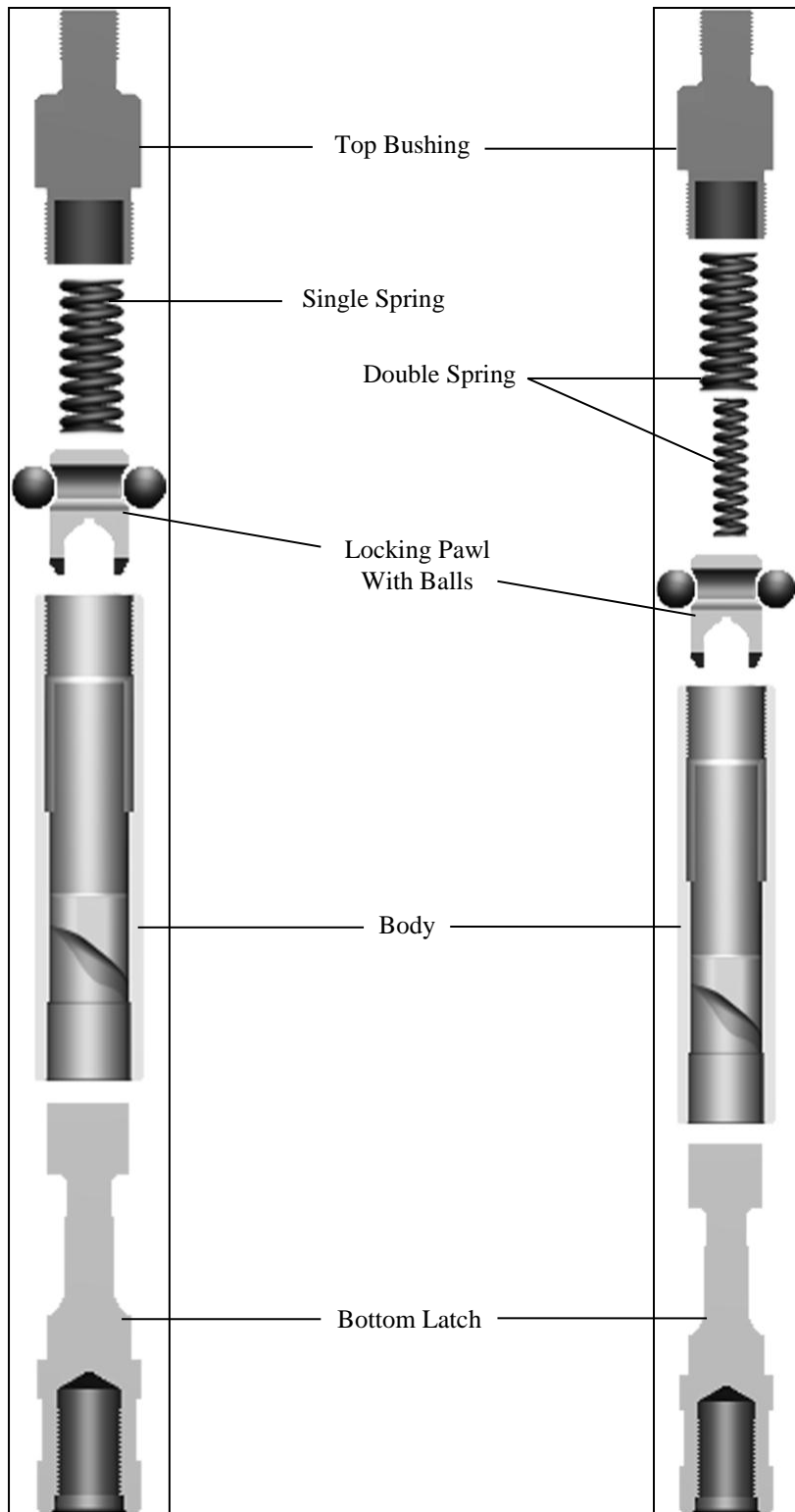

Assembly with single spring (Figure 7)

Assembly with double spring (Figure 8)

DESIGN CONSIDERATION AND LOAD RATINGS¹:

Basic Design Concepts

Static Load: A Static load is defined as a force that is gradually applied to a mechanical component and which does not change its magnitude or direction with respect to time.

In design of machine elements, the following three fundamental equations are used:

$$\sigma_t = \frac{P}{A} \quad \sigma_b = \frac{M_b y}{I} \quad \tau = \frac{M_t R}{J}$$

The above equations are called elementary equations (tensile stress, bending stress, and torsional shear stress respectively). These equations are based on a number of assumptions. One of the assumptions is that there are no discontinuities in the cross-section of the component. However, in practice, discontinuities and abrupt changes in cross-section are unavoidable due to certain features of the components such as oil holes and grooves, keyways and splines, screw threads and shoulders. Therefore, it cannot be assumed that the cross-section of the machine component is uniform. Under these circumstances, the 'elementary' equations do not give correct results.

Fluctuating Stresses: In many applications, the components are subjected to forces, which are not static, but vary in magnitude with respect to time. The stresses induced due to such forces are called fluctuating stresses. It is observed that about 80% of failures of mechanical components are due to fatigue failure resulting from fluctuating stresses.

There are three types of mathematical models for cyclic stresses – *a. fluctuating or alternating stresses; b. repeated stresses; and c. reversed stresses.*

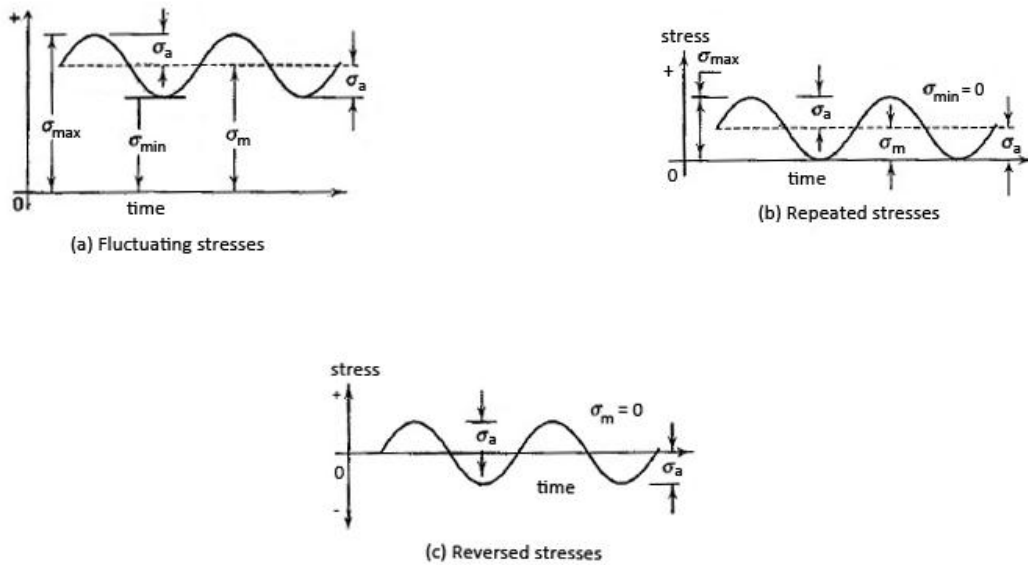

Types of Cyclic Stresses (Figure 9)

The fluctuating or alternating stresses vary in a sinusoidal manner with respect to time. It has some mean value as well as amplitude value fluctuating between two limits *maximum* and *minimum stress*. The stress can be tensile or compressive or partly tensile and partly compressive. The repeated stress varies in a sinusoidal manner with respect to time, but the variation is from zero to some maximum value. The minimum stress is zero in this case and therefore, amplitude stress and mean stress are equal. The reversed stress varies in a sinusoidal manner with respect to time, but it has zero mean stress. In this case, a half portion of the cycle consists of tensile stress and the remaining half consists of compressive stress. There is complete reversal from tension to compression between these two halves therefore, mean stress is zero. In the Figures 9, σ_{\max} and σ_{\min} are maximum and minimum stresses, while σ_m and σ_a are called mean stress and stress amplitude respectively.

Fatigue Failures: It has been observed that materials fail under fluctuating stresses--at a stress magnitude--that is lower than the ultimate tensile strength of the material. Sometimes, the magnitude is even lower than the yield strength. Further, it has been found that the magnitude of the stresses, causing fatigue failure decreases as the number of stress cycles increases. This phenomenon of decreased resistance of the materials to fluctuating stress is the main characteristic of fatigue failure. *Fatigue failure is defined as time delayed fracture under cyclic loading.*

There is a basic difference between failure due to static load and that due to fatigue. The failure due to static load is illustrated by the simple tension test. In this case, the load is gradually applied and there is sufficient time for the elongation of fibers. On the other hand, fatigue failure begins with a crack at some point in the material. The crack is more likely to occur in the following regions:

- (a.) Regions of discontinuity, such as oil holes, keyways, screw threads, etc.
- (b.) Regions of irregularities in machining operations, such as scratches on the surface, stamp mark, inspection marks, etc.
- (c.) Internal cracks due to defects in materials like blow holes.

These regions are subjected to stress concentration due to crack. The crack spreads due to fluctuating stresses, until the cross-section of the component is so reduced that the remaining portion is subjected to sudden fracture. There are two distinct areas of fatigue failure: region indicating slow growth of crack with a fine fibrous appearance; and region of sudden fracture with a coarse granular appearance.

Endurance Limit: *The fatigue or endurance limit of a material is defined as the maximum amplitude of completely reversed stress that the standard specimen can sustain for an unlimited number of cycles without fatigue failure.* Since the fatigue test cannot be conducted for unlimited or infinite number of cycles, 10^6 cycles is considered as sufficient number of cycles to define the endurance limit. *The fatigue life is defined as the number of stress cycles that the standard specimen can complete during the test before the appearance of the first fatigue crack.*

The weakest link in the on-off tool is considered when designing for particular load ratings. Once the bottom latch is in latched position it is subjected to loading. When the pump is in operation, the load on the tool varies. The load varies from down stroke to up stroke and back to down stroke. In order to design the bottom latch for particular load ratings, its loading can be approximated to *repeated* type of cyclic loading. The *repeated* type of cyclic loading is explained in figure 9. The various design parameters are explained with an example. Some of the failures that are observed in on-off tools are shown in the figure 10.1, figure 10.2.

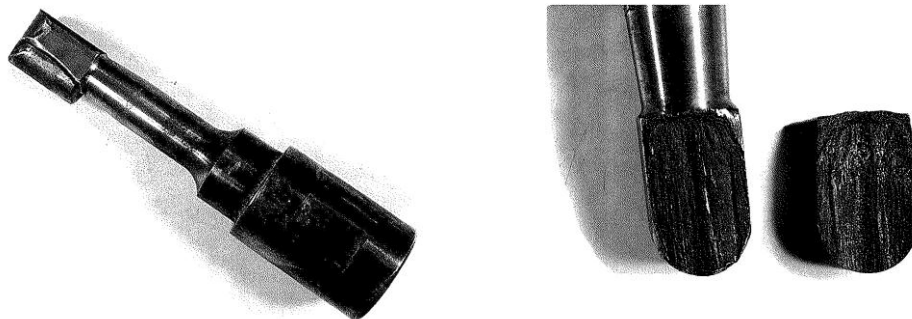

Figure 10.1

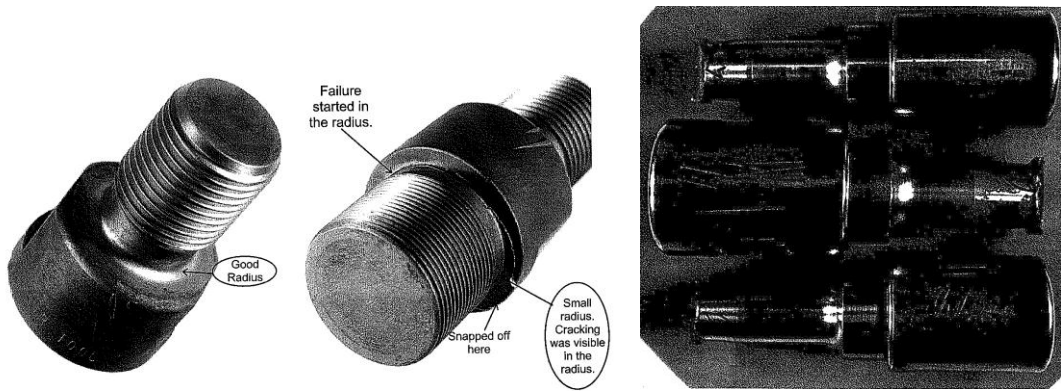

Figure 10.2

Design principle for T-106 – 1-3/16”

Material: Inconel

S_{ut} (tensile strength) = 182300 psi/1256.91 N/mm² and S_{yt} (yield strength) = 134900 psi/930.102 N/mm²

S_e' = Endurance limit stress of a rotating beam specimen subjected to reversed bending stress (N/mm²).

S_e = Endurance limit stress of a particular mechanical component subjected to reversed bending (N/mm²).

For steels = $S_e' = 0.5(S_{ut})$

$$S_e' = 0.5(1256.91) \text{ N/mm}^2$$

$$S_e' = 628.45 \text{ N/mm}^2$$

Relationship between S_e and S_e'

$$S_e = K_a K_b K_c K_d S_e'$$

K_a = Surface finish factor

The surface finish of the rotating beam specimen is polished to mirror finish. While it is impractical to provide such an expensive surface finish, the actual component may not even require such a surface finish. When the surface is poor, there are scratches and geometric irregularities on the surface. These surface scratches serve as stress raisers and result in stress concentration. The endurance limit is reduced due to the introduction of a stress concentration at these scratches. The surface finish factor takes into account the reduction in endurance limit due to the variation in surface finish between the specimen and the actual component. Figure 11 shows the variation of surface finish factor. It should be noted that ultimate tensile strength is also a parameter that affects the surface finish factor. $K_a = 0.68$ from figure 11.

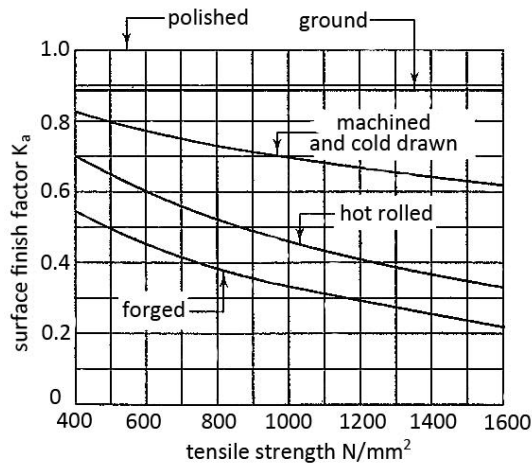

Surface Finish Factor (Figure 11)

K_b = Size factor

The rotating beam specimen is small with a 7.5mm diameter. The larger the machine part, the greater the probability is that a flaw exists somewhere in larger volume. The chances of fatigue failure originating at any one of these flaws is more. The endurance limit, therefore, reduces with an increasing in the size of the component. The size factor K_b takes into account the reduction in endurance limit due to increase in the size of the component. Table 1 shows the values of size factor. $K_b = 0.85$ (for $d = \Phi 0.760''$)

Diameter (d) (mm)	K_b
$d \leq 7.5$	1.00
$7.5 < d \leq 50$	0.85
$d > 50$	0.75

Table 1

K_c = Reliability factor

Reliability is the greater the likelihood that a part will survive, the more is the reliability and lower is the reliability factor. The reliability factor is 1.000 for 50% reliability. This means that 50% of the components will survive in the given set of conditions. Reliability factors are show in table 2. $K_c = 0.814$ (at 99% reliability)

Reliability R (%)	K_c
50	1.000
90	0.897
95	0.868
99	0.814
99.9	0.753
99.99	0.702
99.999	0.659

Table 2

K_d = Modifying factor to account for stress concentration factor

K_t = Theoretical stress concentration factor

K_f = Fatigue stress concentration factor

q = Notch sensitivity factor = 0.8 (In this case)

$$K_f = 1 + q(K_t - 1) \text{ and } K_d = 1/K_f$$

Stress concentration K_t is defined as the localization of high stresses due to the irregularities present in the component and abrupt changes of the cross section. Stress concentration depends on various factors including: variation in properties of materials, load application, abrupt changes in section, discontinuities in the component and machining scratches. At the change of cross-section, the stream lines as well as stress lines bend. When there is sudden change in cross-section, bending of stress lines is very sharp and severe, resulting in stress concentration. Therefore, stress concentration can be greatly reduced by reducing the bending by rounding the corners. However the amount of fillet radius that can be given is a compromise with the reality because it is limited by the mating part. Figure12 illustrates the flow of forces along a component with sudden change in cross section. Figure13 shows the variation of the stress concentration factor for a found shaft with a shoulder fillet in tension by Peterson.

$D = \Phi 1.350''$, $d = \Phi 0.760''$ and fillet radius $r = 0.09375''$ (higher radius could give lower stress concentration, but it is limited by its mating part in order to attain better latching property).

$$K_t = 1.92 \text{ (approx.)}$$

$$K_f = 1 + 0.8(1.92 - 1)$$

$$K_f = 1.736$$

$$K_d = 0.576$$

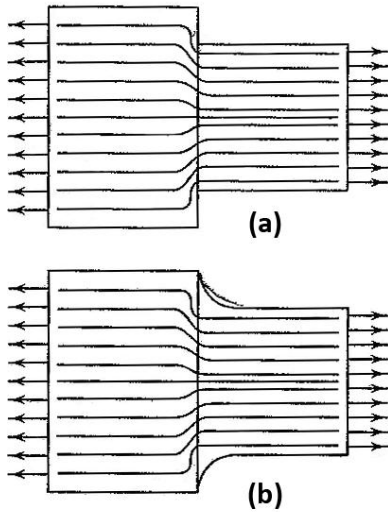

Figure 12 (a) Force flow around sharp corner
(b) Force flow around corner

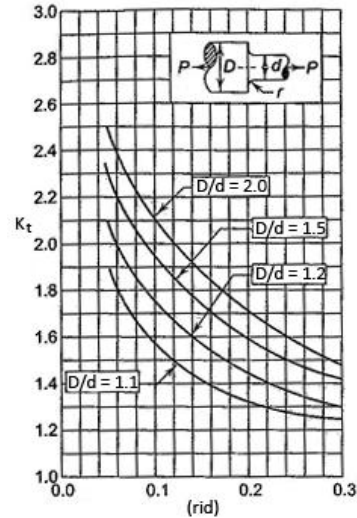

Figure 13 Stress concentration factor for round shaft with shoulder fillet in tension

Therefore, $S_e = (0.68)(0.85)(0.814)(0.576)[628.45] \text{ N/mm}^2$

$$S_e = 170.31 \text{ N/mm}^2$$

In the rotating beam test, the specimen is subjected to bending stress. The bending stress is zero at the center of the cross section and negligible in the vicinity of the center. It is only the outer region near the surface that is subjected to maximum stress. There is more likelihood of a micro crack being present in much higher stress fields of axial loading than in the smaller volume outer region of the rotating beam specimen. Therefore, endurance limit in axial loading is lower than the rotating beam test specimen. Since the bottom latch undergoes axial loading, endurance limit in axial loading is lower than the rotating beam test. For axial loading $(S_e)_a = 0.8S_e$

$$(S_e)_a = 0.8(170.31) \text{ N/mm}^2$$

$$(S_e)_a = 136.24 \text{ N/mm}^2 \text{ or } (S_e)_a = 19759.94 \text{ Psi}$$

Applying Modified Goodman's line equation,
Considering the bottom latch undergoes repeated stresses (refer figure 9),

$$\frac{S_a}{(S_e)_a} + \frac{S_m}{S_{ut}} = 1$$

Since $S_a = S_m$ (for repeating loading)

$$S_a = \left[\frac{1}{19759.94} + \frac{1}{182300} \right] = 1$$

$$S_a = 17827.56 \text{ Psi}$$

At factor of safety = $f_s = 2$

$$\sigma_a = \frac{S_a}{f_s} = \frac{17827.56}{2} = 8913.78 \text{ Psi}$$

Load rating at the neck (weakest section) of the bottom latch:

$$S_a = \frac{P}{A}$$

Therefore, $P=8083.30 \text{ lb}$

Load rating at the neck (weakest section) of the bottom latch with factor of safety:

–

Therefore $P_{fs=2}=4041.65 \text{ lb}$

Load ratings: If the tool is loaded as shown in table 3 it will last for infinite life cycles. The tool should not be loaded more than the load shown in column 1 of the table 3.

Load Ratings (lb)	
99% Reliability	99% Reliability & Factor of safety $f_s=2$
8083.30	4041.65

Table 3

Table 4 shows the recommended load ratings for Don-Nan’s On-Off Tool.

Recommended load ratings for Don-Nan’s On-Off Tools:

SIZE		Load ratings for different materials (lb)		
		INCONEL	4140 Q & T	MONEL
T-130	99% Reliability	35068.1	31067.4	23918.2
	99% Reliability & fs2	17534.1	15533.7	11959.1
T-120	99% Reliability	23355.3	20835.0	16119.2
	99% Reliability & fs2	11677.7	10417.5	8059.6
T-110	99% Reliability	19014.0	16960.7	13119.6
	99% Reliability & fs2	9507.0	8480.3	6559.8
T-100	99% Reliability	11547.9	10354.1	8053.4
	99% Reliability & fs2	5774.0	5177.0	4026.7
T-90	99% Reliability	9019.5	8086.1	6288.1
	99% Reliability & fs2	4509.7	4043.0	3144.1
T-80	99% Reliability	6242.8	5595.8	4350.3
	99% Reliability & fs2	3121.4	2797.9	2175.1

Table 4

REFERENCES:

1. Design of Machine Elements, 2nd Edition by VB Bhandari.